

Contents

2 Hooks



4 Braces



3 Rungs

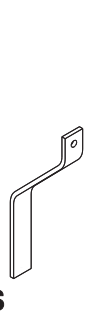

2 Half Braces



6 Bolt Sets



LADDER ASSEMBLY INSTRUCTIONS

1. Assemble Hook, Rung and Brace as shown on right in grayed area. Lay Hook and Brace sides on flat surface, hold rung upright and square with surface while tightening bolt. (See Fig. 1)

2. Completely assemble rest of ladder with bolts FINGER TIGHT ONLY! (See illustration on right)

3. Lay ladder side on flat surface, tighten all bolts on side closest to surface. (See Fig. 2) Now lay opposite side on surface, tighten remaining bolts.

4. Hang ladder in well with hooks fitting securely over top rim. Ladder is ready for use. If additional length is needed contact Adjust-A-Grate for optional ladder extension kit.

Fig. 1

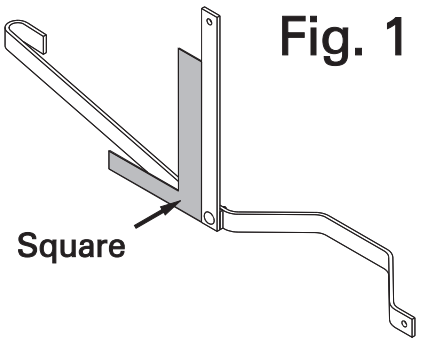

Square

Fig. 2

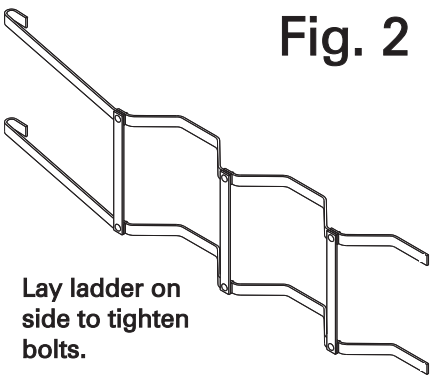

Lay ladder on side to tighten bolts.

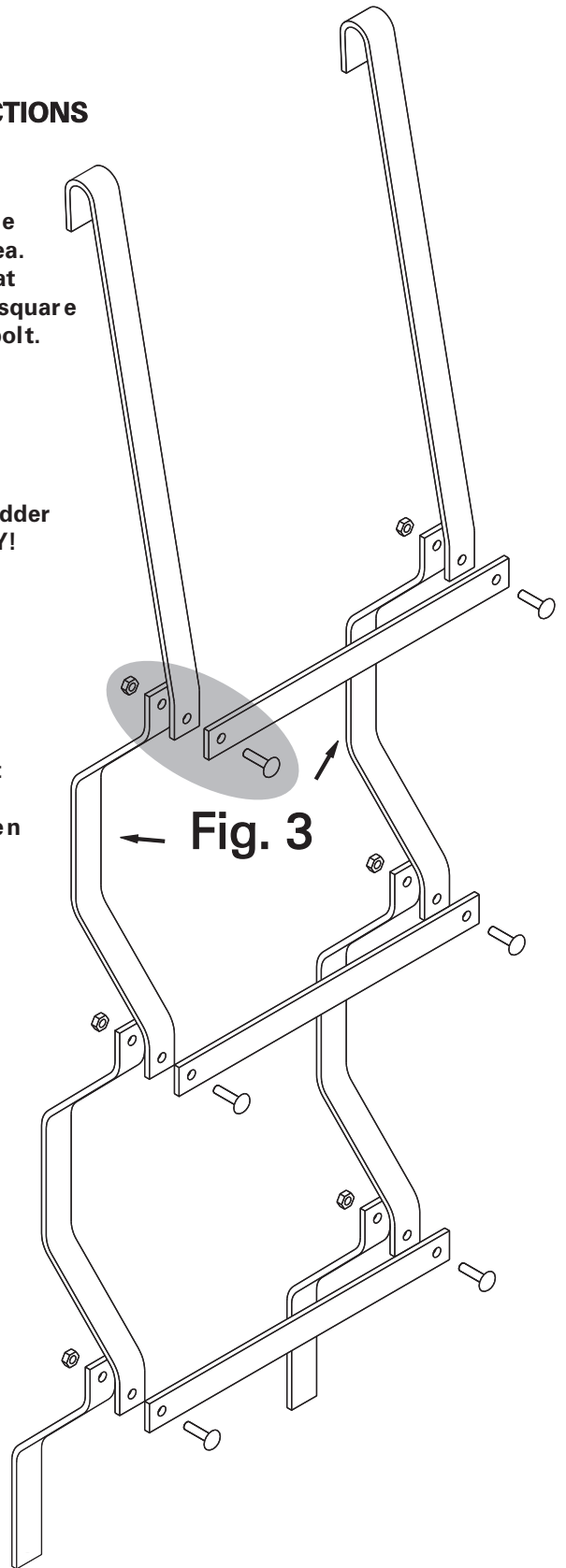

Fig. 3

INSTRUCTIONS FOR OPTIONAL MOUNTING OF LADDER

1. Position ladder in well with hooks fitting securely over top lip. Generally front of well will have best access and less chance of interfering with grating.

2. Mark center of each top brace where it contacts rib of corrugated metal well. (See Fig. 3)

3. Remove ladder from well, lay marked braces over wood block and drill 5/16" hole thru each brace.

4. Reposition ladder in well, drill 3/16" hole into metal well by drilling thru holes in braces.

5. Insert #14x1 Phillips pan head screws (2 provided) into holes and tighten.